

Subject: STEERING PULL / DRIFT - IMPROVED DIAGNOSTIC AND REPAIR PROCEDURE	Bulletin No: 02-007/07
	Last Issued: 11/16/2007

BULLETIN NOTE

This bulletin supersedes the previous bulletin 02-006/06, issued on 10/24/06. The WARRANTY INFORMATION has been revised.

APPLICABLE MODEL(S)/VINS

2003 - 2007 Mazda6

DESCRIPTION

Some vehicles may pull or drift to the left or right while driving on flat level road surfaces. There are several possible causes for this concern:

- Difference between left and right front caster is too great.
- Orientation of front coil spring and structure of front suspension (double-pivot type), torque may pull front lower arm to the left or right.
- Suspension assembly variation causing preload to remain on the suspension.
- Suspension sensitivity.

Strut bearings have been added at mass-production to front strut mounts to cancel torque event.

Customers having this concern should have their vehicle repaired using the following repair procedure.

REPAIR PROCEDURE

Driving Inspection:

1. Test drive vehicle according to Pull/Drift Specifications below to verify vehicle pulls/drifts left or right.

NOTE: Confirm pull/drift is not caused by the following factors:

- Road crown or wheel track during constant speed driving.
- Different size tires or uneven tire wear between left and right tires.
- Brake drag on any wheel.
- Excessive ball joint or steering linkage looseness.
- Measure height from center of wheel to fender brim. The difference between left and right should be no greater than 0.39 in.

Pull/Drift Specifications:

- Driver and passenger
 - Road crown = -0.5 to 2.0 degrees
 - Wind velocity = 0 mph
 - Vehicle speed = 55 mph
 - Pull/Drift rate = 1 complete lane in 7 seconds or less
- If vehicle does not pull/drift according to Pull/Drift Specifications, return vehicle to customer.
 - If vehicle does pull/drift according to Pull/Drift Specifications, proceed to next step.
2. Check tire pressure.
 - If tire pressure is too low or too high, correct tire pressure as needed; test drive vehicle.
 - If tire pressure is correct, proceed to next step.
 3. Check power steering effort.
 - If power steering effort is uneven, replace power steering rack; test drive vehicle.
 - If power steering effort is okay, proceed to next step.
 4. Verify steering wheel centering.
 - If steering wheel is off-center, realign steering wheel.
 - If steering wheel is not off-center and vehicle is produced before April 5, 2004, proceed to "A. STRUT MOUNT KIT INSTALLATION."
 - If steering wheel is not off-center and vehicle is produced after April 5, 2004, proceed to "B. 4-WHEEL ALIGNMENT."

NOTE: Vehicles produced after April 5, 2004 already have the STRUT MOUNT KIT INSTALLED, so it is not necessary to install it.

A. STRUT MOUNT KIT INSTALLATION

NOTE: "A. STRUT MOUNT KIT INSTALLATION" only applies to vehicles produced before April 5, 2004.

See Parts Information table for new part numbers (A - F).

New Parts	New Parts	Parts To Be Reused
(A) Strut Bearing	(D) Spring Seat Rubber	(1) Coil Spring
(B) Strut Mount Rubber	(E) Dust Boot	(2) Bound Stopper
(C) Spring Seat	(F) 6mm Temporary Bolt	(3) Shock Absorber

1. Remove and disassemble existing front strut assembly according to the Workshop Manual (section 02-13 FRONT SHOCK ABSORBER AND SPRING REMOVAL/INSTALLATION).
2. Reassemble front strut assembly equipped with strut bearing.

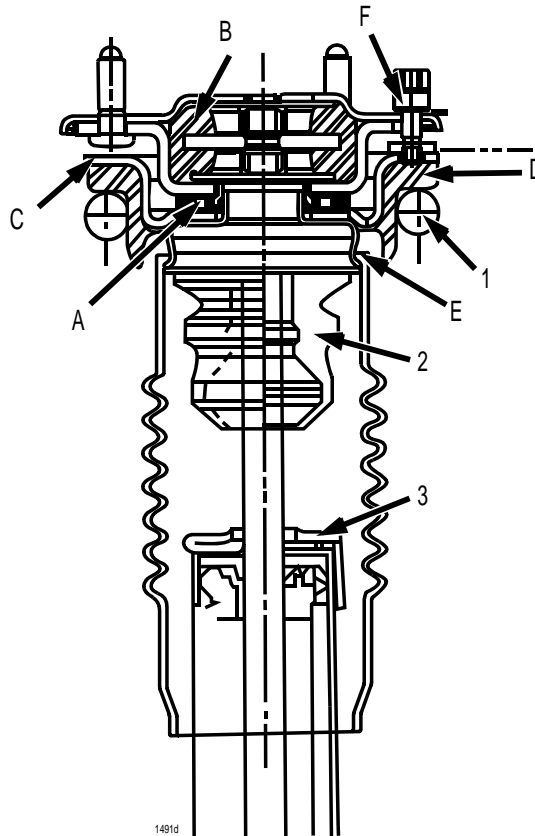

- a. Fit spring seat rubber (D) with spring seat (C).
- b. Set bound stopper (2) in the parts assembled.
- c. Install dust boot (E) on the parts assembled.
- d. Make sure strut bearing (A) is installed on top of spring seat (C).

CAUTION: Pay attention to direction of strut bearing (A) as shown below.

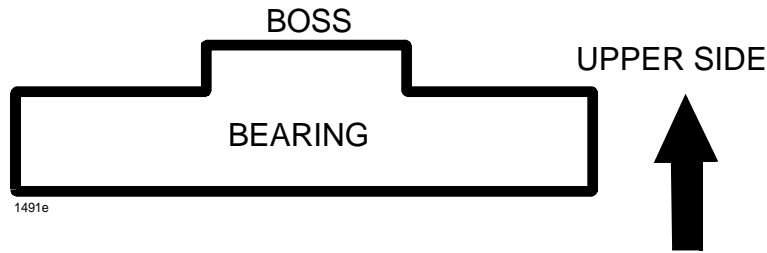

- e. Engage boss part of strut bearing (A) in bottom hole of strut mount rubber (B), and install 6mm temporary bolt (F) through hole to temporarily secure strut mount rubber, strut bearing, and spring seat.
- f. Assemble strut assembly by installing coil spring (1) and shock absorber (3) on the parts assembled according to the Workshop Manual (section 02-13 FRONT SHOCK ABSORBER AND SPRING REMOVAL/INSTALLATION).

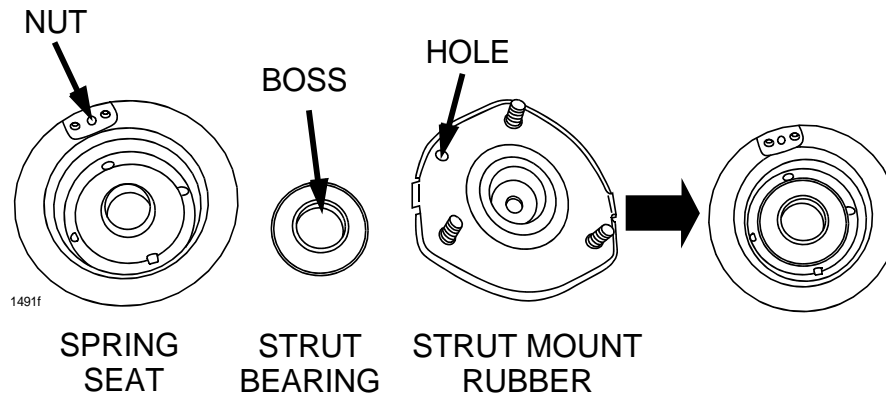

3. Remove 6mm temporary bolt (F).
4. Lower vehicle to ground.
5. Test drive vehicle.
 - If pull/drift is eliminated, return vehicle to customer.
 - If pull/drift is not eliminated, proceed to "B. 4-WHEEL ALIGNMENT."

B. 4-WHEEL ALIGNMENT

1. Perform 4-wheel alignment using the following alignment specifications (alignment specs are in degrees).

SPORT SEDAN, 5-DOOR (Unloaded *1)

Item	Empty	1/4	1/2	3/4	Full
Fuel gauge indication	Empty	1/4	1/2	3/4	Full
Front total toe-in	0.18°+/-0.37°	0.18°+/-0.37°	0.18°+/-0.37°	0.18°+/-0.37°	0.18°+/-0.37°
Front caster angle*2	4.20°+/-1°	4.23°+/-1°	4.26°+/-1°	4.31°+/-1°	4.36°+/-1°
Front camber angle*2	-0.27°+/-1°	-0.27°+/-1°	-0.27°+/-1°	-0.29°+/-1°	-0.29°+/-1°
Rear total toe-in	0.18°+/-0.37°	0.18°+/-0.37°	0.18°+/-0.37°	0.18°+/-0.37°	0.18°+/-0.37°
Rear camber angle*2	-0.98°+/-1°	-1.00°+/-1°	-1.03°+/-1°	-1.07°+/-1°	-1.10°+/-1°
Thrust angle	0°+/-0.80°	0°+/-0.80°	0°+/-0.80°	0°+/-0.80°	0°+/-0.80°

*1: Engine coolant and engine oil are at specified level. Spare tire, jack and tools are in designated position.

*2: Difference between left and right must not exceed 1.50°.

SPORT WAGON (Unloaded *1)

Item	Empty	1/4	1/2	3/4	Full
Fuel gauge indication	Empty	1/4	1/2	3/4	Full
Front total toe-in	0.18°+/-0.37°	0.18°+/-0.37°	0.18°+/-0.37°	0.18°+/-0.37°	0.18°+/-0.37°
Front caster angle*2	4.06°+/-1°	4.11°+/-1°	4.15°+/-1°	4.20°+/-1°	4.23°+/-1°
Front camber angle*2	-0.27°+/-1°	-0.27°+/-1°	-0.27°+/-1°	-0.29°+/-1°	-0.29°+/-1°
Rear total toe-in	0.18°+/-0.37°	0.18°+/-0.37°	0.18°+/-0.37°	0.18°+/-0.37°	0.18°+/-0.37°
Rear camber angle*2	-0.98°+/-1°	-1.00°+/-1°	-1.03°+/-1°	-1.07°+/-1°	-1.10°+/-1°
Thrust angle	0°+/-0.80°	0°+/-0.80°	0°+/-0.80°	0°+/-0.80°	0°+/-0.80°

*1: Engine coolant and engine oil are at specified level. Spare tire, jack and tools are in designated position.

*2: Difference between left and right must not exceed 1.50°.

2. Check for deformation of control arms, brackets, and bushings.
 - If any item is out of specification, adjust front or rear toe-in within specification and repair any deformation of control arms, brackets, and bushings.
 - If all items are within specification and vehicle still pulls, proceed to "C. FRONT UPPER CONTROL ARM REPLACEMENT."
3. Test drive vehicle.
 - If pull/drift is eliminated, return vehicle to customer.
 - If pull/drift is not eliminated, proceed to "C. FRONT UPPER CONTROL ARM REPLACEMENT."

C. FRONT UPPER CONTROL ARM REPLACEMENT

1. Using caster values taken from alignment check, and information from Tables 1 or 2 below, select correct offset front upper control arm(s) for installation onto vehicle according to Workshop Manual (section 02-13 FRONT UPPER CONTROL ARM REMOVAL/INSTALLATION).

NOTE: Vehicles have a tendency to go opposite the side with greater caster.

- **If vehicle is pulling RIGHT, refer to Table 1 below.**
 - **If vehicle is pulling LEFT, refer to Table 2 below.**
2. Check wheel alignment.
 3. Test drive vehicle.
 - If pull/drift is eliminated, return vehicle to customer.
 - If pull/drift is not eliminated, proceed to "D. FRONT LOWER CONTROL ARM ADJUSTMENT."

TABLE 1 (for vehicles pulling right):

To make vehicle go LEFT, either increase caster on right so it is greater than caster on left, or decrease caster on left so it is less than caster on right.

Front Upper Control Arm	Degree of Change
GPYA-34-250	- 0.4°
GPYA-34-200	+ 0.4°

TABLE 2 (for vehicles pulling left):

To make vehicle go RIGHT, either increase caster on left so it is greater than caster on right, or decrease caster on right so it is less than caster on left.

Front Upper Control Arm	Degree of Change
GPYB-34-250	+ 0.4°
GPYB-34-200	- 0.4°

D. FRONT LOWER CONTROL ARM ADJUSTMENT

The front tires should contact the ground during Steps 2-10, otherwise, the applied stress on the lower arm bushings will not be enough and the results will be less effective.

WARNING: Do not start engine while vehicle is on hoist. Power steering is not necessary for this procedure. A running engine can result in all manner of added dangers to the people around you.

NOTE: Two (2) people are required to perform steps below.

1. Place one person in vehicle to hold steering wheel.
2. Safely secure vehicle on 4-post hoist and raise vehicle slightly. Keep front tires in contact with the ground.
3. Hold steering wheel in center position.
4. Loosen bolts "A" and "C" on both sides of front suspension.
 - Bolt "A": Front Lower Control Arm and Perimeter Frame
 - Bolt "C": Front Lower Control Arm and Damper Fork

NOTE: DO NOT REMOVE BOLTS "A" OR "C".

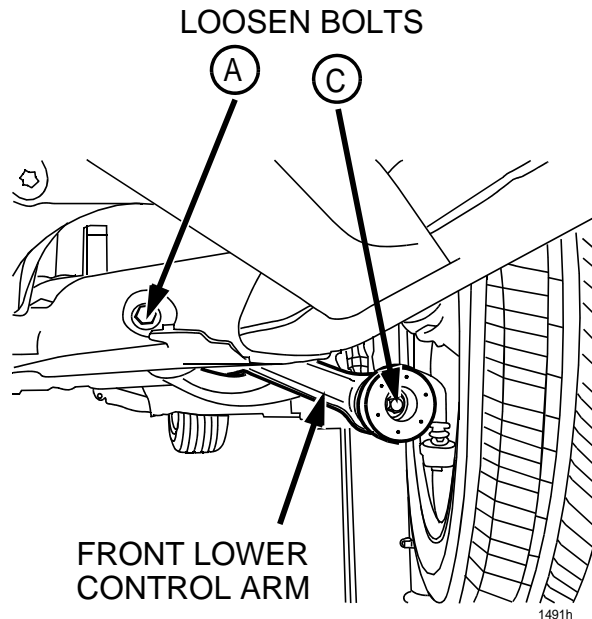

5. Loosen bolt "B" on both sides of front suspension.
 - Bolt "B": Rear Lower Control Arm and Perimeter Frame

NOTE: DO NOT REMOVE BOLT "B".

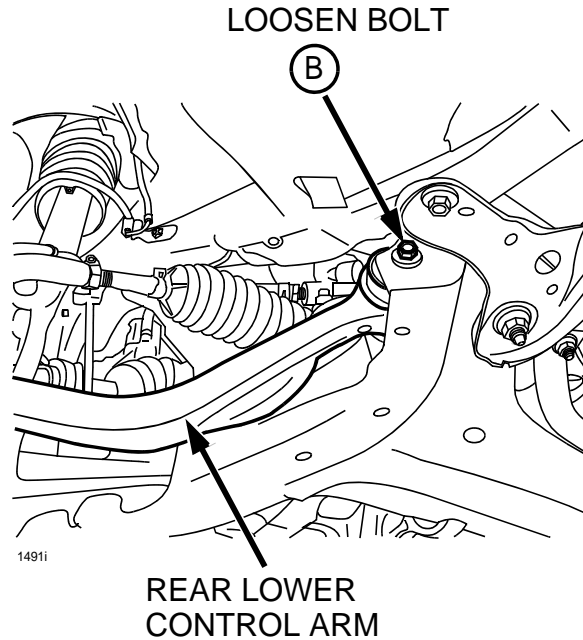

6. If vehicle pulls/drifts to the RIGHT, turn and hold steering wheel to full LEFT locked position.
If vehicle pulls/drifts to the LEFT, turn and hold steering wheel to full RIGHT locked position.

NOTE: Do not allow steering wheel to move during repair steps below. Keep constant pressure on steering wheel at all times.
7. Lower full weight of vehicle to ground.
8. Jounce front of vehicle at left and right sides of front bumper several times to reposition front suspension components.
9. Raise vehicle on hoist.
10. Tighten bolts "A", "B" and "C".
Tightening Torque: 68.67 - 93.22 ft-lbf. (93.1 - 126.4 Nm)
11. Return steering wheel to center position.
12. Lower vehicle to ground.
13. Test drive vehicle to verify repair.

PART(S) INFORMATION

TABLE 1

Part Number	Description	Qty.	Notes
GN1G-34-38Y	Strut Mount Kit	2	Contains A, B, C and F
GM6A-34-012A	Spring Seat Rubber	2	D
GM6A-34-015	Dust Boot	2	E

NOTE:

- "A. STRUT MOUNT KIT INSTALLATION" only applies to vehicles produced before April 5, 2004.
- Parts listed in Table 1 are only applicable to the "A. STRUT MOUNT KIT INSTALLATION" repair. Do not order parts if "A. STRUT MOUNT KIT INSTALLATION" repair will not be performed.

TABLE 2

Part Number	Description	Qty.	Degree of Change
GPYB-34-250	Upper Control Arm (Left)	1	+ 0.4°
GPYA-34-250	Upper Control Arm (Left)	1	- 0.4°
GPYA-34-200	Upper Control Arm (Right)	1	+ 0.4°
GPYB-34-200	Upper Control Arm (Right)	1	- 0.4°

NOTE: Parts listed in Table 2 are only applicable to the "C. FRONT UPPER CONTROL ARM REPLACEMENT" repair. Do not order parts if "C. FRONT UPPER CONTROL ARM REPLACEMENT" repair will not be performed.

WARRANTY INFORMATION

NOTE:

- This warranty information applies only to verified customer complaints on vehicles eligible for warranty repair. Refer to the Warranty Wizard for warranty term information.
- Additional diagnostic time cannot be claimed for this repair.

	Driving Inspection (For vehicles produced after April 05, 2004)	Driving Inspection A. Strut Mount Kit Installation * (For vehicles produced before April 05, 2004)
Warranty Type	A	A
Symptom Code	32	32
Damage Code	9J	9J
Part Number Main Cause	GK2A-34-711A (pull right) GK2A-34-911A (pull left)	GK2A-34-711A (pull right) GK2A-34-911A (pull left)
Quantity	0	0
Operation Number / Labor Hours:	YY448XR1 / 0.4 Hrs. (2.3L Eng.) YY448XR1 / 0.4 Hrs. (3.0L Eng.)	YY449XR1 / 1.6 Hrs. (2.3L Eng.) YY449XR1 / 1.5 Hrs. (3.0L Eng.)

	Driving Inspection B. 4-Wheel Alignment (For vehicles produced after April 05, 2004)	Driving Inspection A. Strut Mount Kit Installation * B. 4-Wheel Alignment (For vehicles produced before April 05, 2004)
Warranty Type	A	A
Symptom Code	32	32
Damage Code	9J	9J
Part Number Main Cause	GK2A-34-711A (pull right) GK2A-34-911A (pull left)	GK2A-34-711A (pull right) GK2A-34-911A (pull left)
Quantity	0	0
Operation Number / Labor Hours:	YY448XR2 / 1.7 Hrs. (2.3L Eng.) YY448XR2 / 1.7 Hrs. (3.0L Eng.)	YY449XR2 / 2.9 Hrs. (2.3L Eng.) YY449XR2 / 2.8 Hrs. (3.0L Eng.)

(*) - "A. STRUT MOUNT KIT INSTALLATION" only applies to vehicles produced before April 5, 2004.

	Driving Inspection B. 4-Wheel Alignment C1. (One side) - Upper Control Arm Installation (includes wheel alignment) (For vehicles produced after April 05, 2004)	Driving Inspection A. Strut Mount Kit Installation * B. 4-Wheel Alignment C1. (One side) - Upper Control Arm Installation (includes wheel alignment) (For vehicles produced before April 05, 2004)
Warranty Type	A	A
Symptom Code	32	32
Damage Code	9J	9J
Part Number Main Cause	GK2A-34-711A (pull right) GK2A-34-911A (pull left)	GK2A-34-711A (pull right) GK2A-34-911A (pull left)
Quantity	0	0
Operation Number / Labor Hours:	YY448XR3 / 2.3 Hrs. (2.3L Eng.) YY448XR3 / 2.4 Hrs. (3.0L Eng.)	YY449XR3 / 3.5 Hrs. (2.3L Eng.) YY449XR3 / 3.5 Hrs. (3.0L Eng.)

	Driving Inspection B. 4-Wheel Alignment C2. (Both sides) - Upper Control Arm Installation (includes wheel alignment) (For vehicles produced after April 05, 2004)	Driving Inspection A. Strut Mount Kit Installation * B. 4-Wheel Alignment C2. (Both sides) - Upper Control Arm Installation (includes wheel alignment) (For vehicles produced before April 05, 2004)
Warranty Type	A	A
Symptom Code	32	32
Damage Code	9J	9J
Part Number Main Cause	GK2A-34-711A (pull right) GK2A-34-911A (pull left)	GK2A-34-711A (pull right) GK2A-34-911A (pull left)
Quantity	0	0
Operation Number / Labor Hours:	YY448XR4 / 2.7 Hrs. (2.3L Eng.) YY448XR4 / 2.8 Hrs. (3.0L Eng.)	YY449XR4 / 3.9 Hrs. (2.3L Eng.) YY449XR4 / 3.9 Hrs. (3.0L Eng.)

(*) - "A. STRUT MOUNT KIT INSTALLATION" only applies to vehicles produced before April 5, 2004.

	Driving Inspection B. 4-Wheel Alignment C1. (One side) - Upper Control Arm Installation (includes wheel alignment) D. Lower Control Arm Adjustment (For vehicles produced after April 05, 2004)	Driving Inspection A. Strut Mount Kit Installation * B. 4-Wheel Alignment C1. (One side) - Upper Control Arm Installation (includes wheel alignment) D. Lower Control Arm Adjustment (For vehicles produced before April 05, 2004)
Warranty Type	A	A
Symptom Code	32	32
Damage Code	9J	9J
Part Number Main Cause	GK2A-34-711A (pull right) GK2A-34-911A (pull left)	GK2A-34-711A (pull right) GK2A-34-911A (pull left)
Quantity	0	0
Operation Number / Labor Hours:	YY448XR5 / 2.8 Hrs. (2.3L Eng.) YY448XR5 / 3.4 Hrs. (3.0L Eng.)	YY449XR5 / 4.0 Hrs. (2.3L Eng.) YY449XR5 / 4.5 Hrs. (3.0L Eng.)

	Driving Inspection B. 4-Wheel Alignment C2. (Both sides) - Upper Control Arm Installation (includes wheel alignment) D. Lower Control Arm Adjustment (For vehicles produced after April 05, 2004)	Driving Inspection A. Strut Mount Kit Installation * B. 4-Wheel Alignment C2. (Both sides) - Upper Control Arm Installation (includes wheel alignment) D. Lower Control Arm Adjustment (For vehicles produced before April 05, 2004)
Warranty Type	A	A
Symptom Code	32	32
Damage Code	9J	9J
Part Number Main Cause	GK2A-34-711A (pull right) GK2A-34-911A (pull left)	GK2A-34-711A (pull right) GK2A-34-911A (pull left)
Quantity	0	0
Operation Number / Labor Hours:	YY448XR6 / 3.2 Hrs. (2.3L Eng.) YY448XR6 / 3.8 Hrs. (3.0L Eng.)	YY449XR6 / 4.4 Hrs. (2.3L Eng.) YY449XR6 / 4.9 Hrs. (3.0L Eng.)